

WIRING DIAGRAM

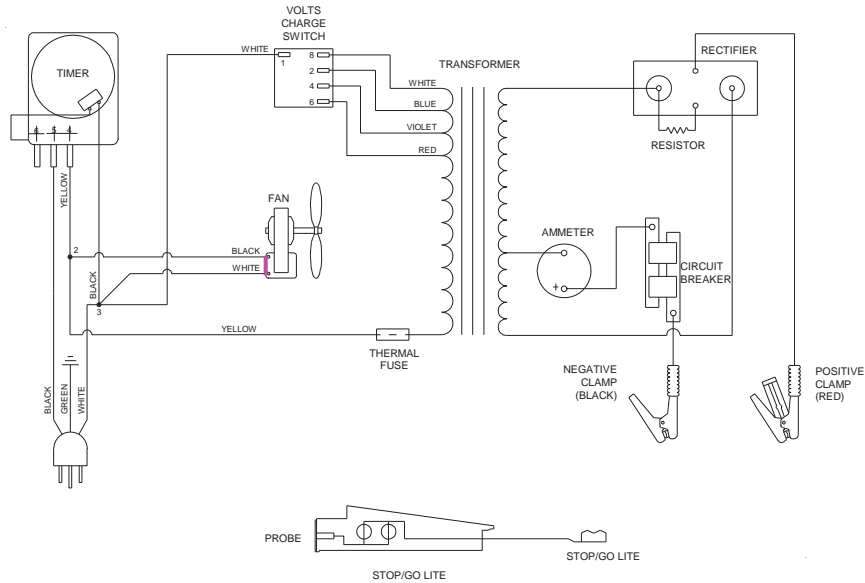

MODEL 6010B PARTS LIST

Item	Description	Part No.
1	Transformer.....	611386
2	Rectifier.....	610364
3	Fan Blade.....	610189
4	Fan Motor.....	610190
5	Timer.....	611245
6	Switch w/knob (1).....	611187
7	Amps Charge Meter.....	605204
8	AC Cord.....	611248
9	DC Cable set.....	611134
10	DC Circuit Breaker (1).....	610069
11	Front/Base/Back Panel.....	611387
12	Stop/Go Lite.....	604579
13	Clamps (1 pair, includes jaws).....	6202
14	Jaw Kit (repairs 1 clamp).....	610970
15	Knob (1).....	603147
Not shown		
	Top Panel.....	611025
	Side Panel (2).....	610071
	Handle.....	610057

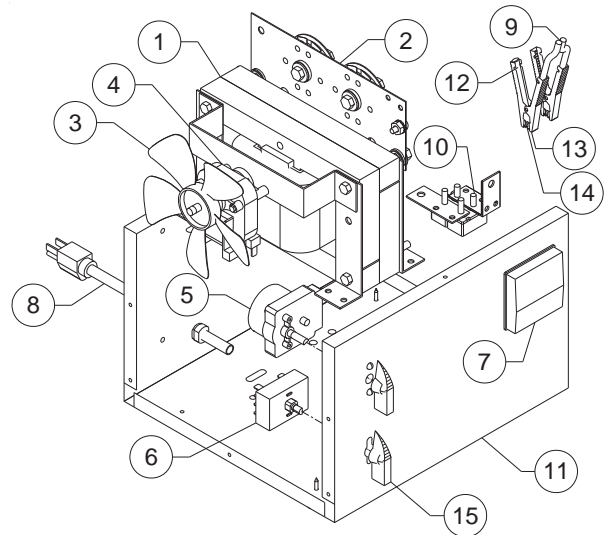

MAINTENANCE INSTRUCTIONS

Worn clamps and jaws should be replaced. Worn parts can lead to poor connections and present a safety hazard. See parts list for part number of jaw and clamp kits. Any Maintenance or repair of this unit that involves disassembly of the cabinet should be done only by a qualified serviceman. Incorrect reassembly may result in a risk of electric shock when the unit is subsequently used.